



QTL1
A4

PART OF FM PLL Tx ASP FM05TX	REV No Mk I	DATE 5-4-2000	FILE ASP FM05TX DISPLAY UNIT	APPROVED	Project No 12310	Date 5-4-00	PCB No 12310-5	Scale 	Angle 	TITLE DISPLAY UNIT 5 DIGITS 9 KEYS	
PROTOTYPE 23-3-2000	FINAL 10-4-2000	TESTED 2-4-2000	SCHEMA No 12310-5	HARDWARE DESIGNER S. Papadimitriou	HARDWARE ENGINEER S. Papadimitriou					ASPiSYS Ltd. P.O.BOX 14386 ATHENS 11510	Sh1
MEMORY	MPU	COM	SW No	SOFTWARE DESIGNER A. Papadimitriou	SOFTWARE ENGINEER A. Papadimitriou						

VCO

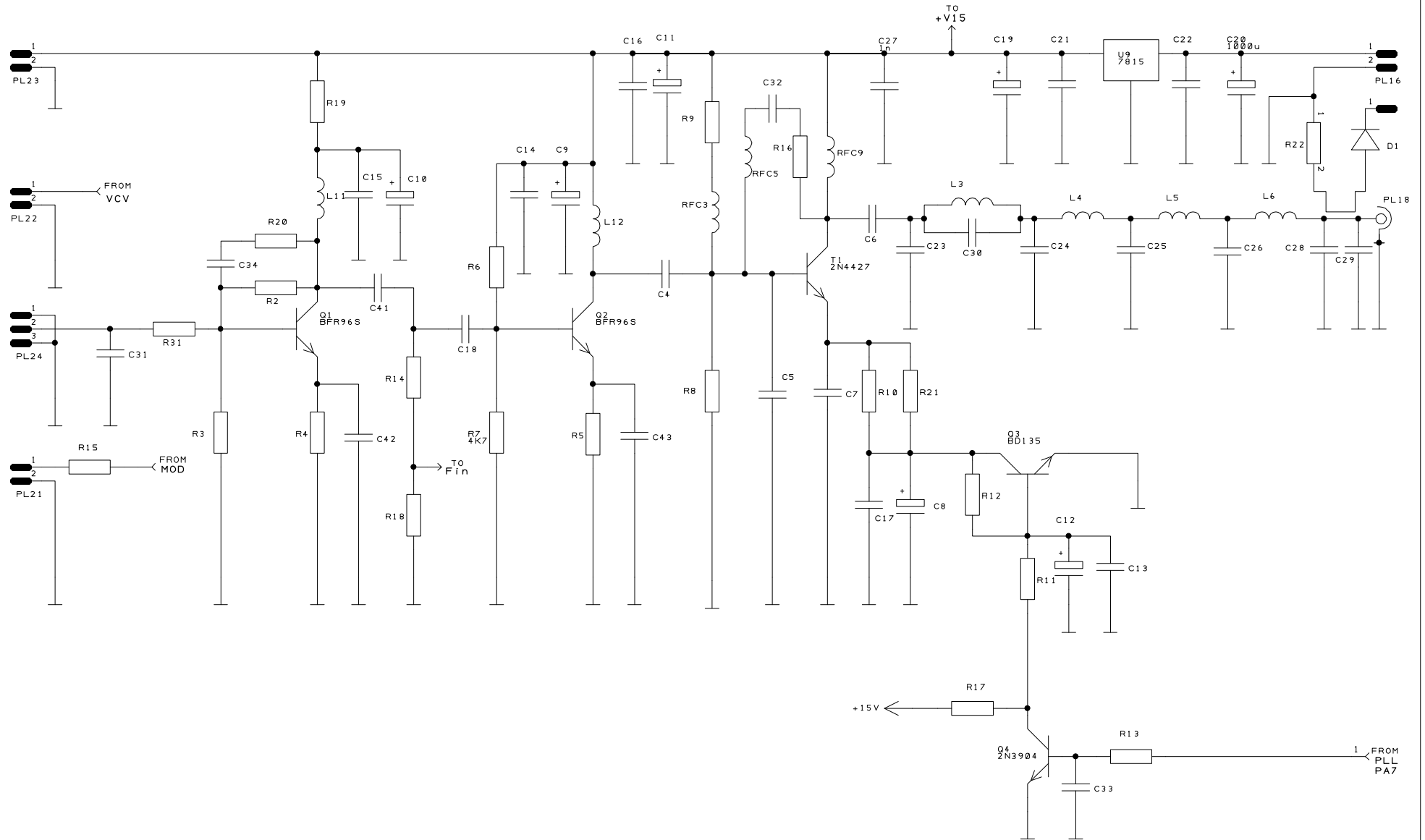

QTL3
A4

PART OF FM PLL TX ASP FM5E	REV No Mk I Mk II Mk III	DATE 15-6-84 11-2-87 22-3-00	FILE ASP FM05TX RF AMPL UNIT	APPROVED DD	Project No 12310	Date 22-3-2000	PCB No 12310-2	Scale 	Angle	TITLE FM BROADBAND RF AMPLIFIER 87-108MHz
PROTOTYPE 10-2-00	FINAL 19-3-00	END DATE 21-3-00	SCHEMA No 12310-2	HARDWARE DESIGNER S. Papadimitriou			CONTRACT			ASPiSYS Ltd. P.O. BOX 14386 ATHENS 11510
MEMORY	MPU	COM	SW No	SOFTWARE DESIGNER A. Papadimitriou			COMPANY CONTACT			

SH 1

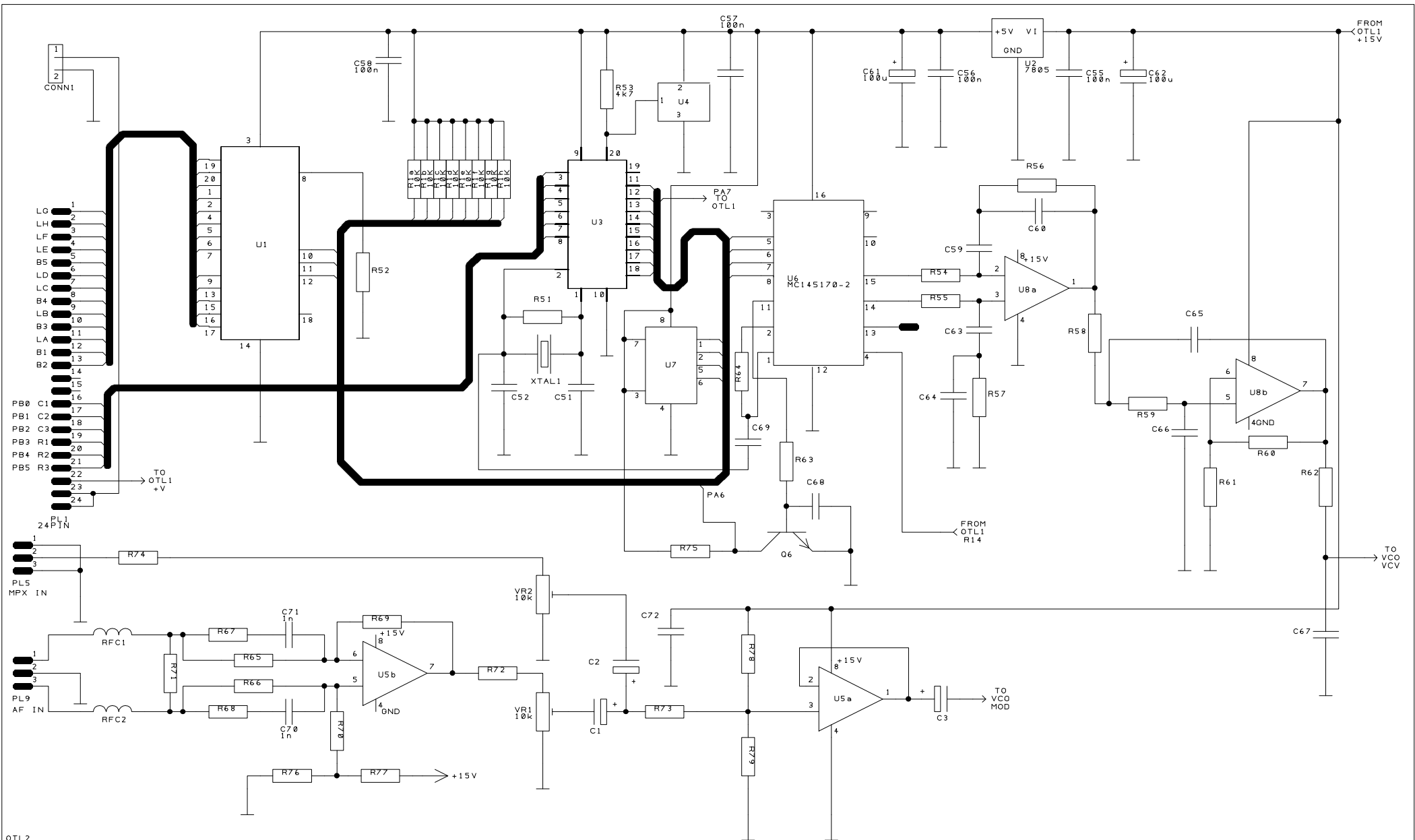

QTL2 A4		PART OF ASP FM05TX		REV No Mk I	DATE 8-10-99	FILE MPU & PLL UNIT ASP FM05TX	APPROVED DD	Project No 12310	Date 21-11-1999	PCB No 12310-4	Scale	Angle	TITLE MPU & PLL UNIT WITH AUDIO PRE
PROTOTYPE 14-10-99	FINAL 20-11-99	TESTED 12-11-99	SCHEMA No 12310-4	HARDWARE DESIGNER S. Papadimitriou			HARDWARE ENGINEER						
MEMORY 2k EE	MPU OTP	COM NO	SW No 12311	SOFTWARE DESIGNER A. Papadimitriou			SOFTWARE ENGINEER						
												ASP i SYS Ltd. Sh2 P.O. BOX 14386 ATHENS 11510	